



MINISTRY OF PUBLIC WORKS, TRANSPORTS AND HOUSING
NATIONAL CENTER FOR SEISMIC RISK REDUCTION, NCSRR
 a os. Pantelimon nr. 266, Bucharest, Romania
 Tel. – Fax. 00 421 255 16 67

JAPANESE TECHNICAL COOPERATION PROJECT
ON THE REDUCTION OF SEISMIC RISK
FOR BUILDINGS AND STRUCTURES
 &
NATIONAL CENTER FOR SEISMIC RISK REDUCTION
 - short presentation -

Background of the Japanese Technical Cooperation Project on the
Reduction of Seismic Risk for Buildings and Structures

The Ministry of Public Works, Transports and Housing of Romania and the Japanese International Cooperation Agency, JICA signed on August 1st, 2002, the Technical Cooperation Project entitled *The Japanese Technical Cooperation Project on the Reduction of Seismic Risk for Buildings and Structures*. The Project started on October 1st, 2002 in the frame of the *National Center for Seismic Risk Reduction* as implementing agency. The Project is launched in the year that celebrates 100 years of diplomatic relations between Japan and Romania.

The scope of the Project is to strengthen the capacity of earthquake related disasters prevention activities in Romania.

The Project is the output of four years of intensive efforts made by professionals from the *Technical University of Civil Engineering Bucharest*, the *National Institute for Research & Development in Construction and Construction Economics-INCERC Bucharest*, *Ministry of Public Works, Transports and Housing, Romania*, *Japanese International Cooperation Agency*, *Building Research Institute, Tsukuba* and *National Institute for Land and Infrastructure Management, Tsukuba*.

Project schedule and financing

The duration of the Project is five years starting with October 2002. The schedule is as follows:

- ✓ First year: investigation of Romanian evaluation and retrofitting techniques; study of Japanese evaluation and retrofitting techniques ;
- ✓ Second year: collection of existing data on strong Romanian earthquakes, soil properties and vulnerable buildings;
- ✓ Third year: performing structural and soil tests and investigations;
- ✓ Forth year: preparation of technical manuals on building retrofitting, on seismic motion evaluation and on soil conditions;
- ✓ Fifth year: preparation of regulation and norms on seismic evaluation and retrofit of buildings; preparation of documents for revision of seismic design codes in Romania.

During the Project period, 16 young Romanian engineers will be trained in Japan, 26 Japanese experts will work in Romania and equipment for seismic instrumentation of the Romanian territory, dynamic characterization of soil and seismic testing of structures rising up approximately to 260 million yens (i.e. 2.17 million USD) will be donated to the Romanian State by the *Japanese International Cooperation Agency, JICA*. The total cost of the Project is roughly 630 million yens (i.e. 5.27 million USD).

National Center for Seismic Risk Reduction

The implementing agency of the *Japanese Technical Cooperation Project on the Reduction of Seismic Risk for Buildings and Structures* is the *National Center for Seismic Risk Reduction*, as a public institution of national interest, a specialized legal entity, subordinated to the *Ministry of Public Works, Transports and Housing* of Romania. The main activities of the *National Center* are as follows:

- ✓ issuing of new technologies for retrofitting the earthquake vulnerable buildings and structures;
- ✓ issuing of new codes for seismic resistant design;
- ✓ seismic instrumentation of Bucharest and of densely built areas;
- ✓ transfer of state state-of-the-art knowledge in domain of anti-seismic protection to specialists and issuing documentation regarding education of the population for preventing the seismic consequences;
- ✓ ensures the development of technical knowledge by stages of training, studies and documentation, seminars, courses and lecturers in Romania and abroad;
- ✓ promoting the international cooperation in domain of seismic risk management;
- ✓ publish and print studies and publications in the specific field of activity;
- ✓ other activities pertaining the projects implementation.

The *Center* activities will be carried out in the partnership by the *Technical University of Civil Engineering Bucharest* and the *National Institute for Research-Development in Construction Economics –INCERC Bucharest* by organizing and using jointly the testing facilities.

The Director of the *National Center* was appointed Assoc. Prof. dr. Radu Vacareanu.

The activities are carried out in four divisions, namely:

- ✓ Division 1 - Building Retrofitting and Design Codes
- ✓ Division 2 - Seismic Observation Network
- ✓ Division 3 – Technical Experimentation for Soil and Structures
- ✓ Division 4 – Dissemination of Knowledge and Training of Engineers

The running expenses and the investments of the *Center* will be financed from extra-budgetary incomes and state budget allocations through the *Ministry of Public Works, Transports and Housing* budget.

Equipments to be provided within the Japanese Technical Cooperation Project on the Reduction of Seismic Risk for Buildings and Structures

The structural testing equipments will be provided by *Japanese International Cooperation Agency* and will be placed at the *Technical University of Civil Engineering* of Bucharest. It will consist of a steel reaction frame, loading and data acquisition and processing systems, to be shipped by the end of year 2003. The reaction frame is similar to the one in *Building Research Institute*, Tsukuba, Japan. The objectives of structural testing program are:

- ✓ Test of the representative vulnerable structural systems and components;
- ✓ Test of the efficient and innovative Japanese retrofitting techniques;
- ✓ Development of constitutive laws for vulnerable structural components.

The following load combinations will be possible with the provided equipment: 1) Bending with shear for beams testing, 2) Bending with shear and axial load for columns, shear walls and portal frames. The maximum weight of tested specimens is 7to and the maximum dimensions of the tested specimens are 2.5m by 3 m.

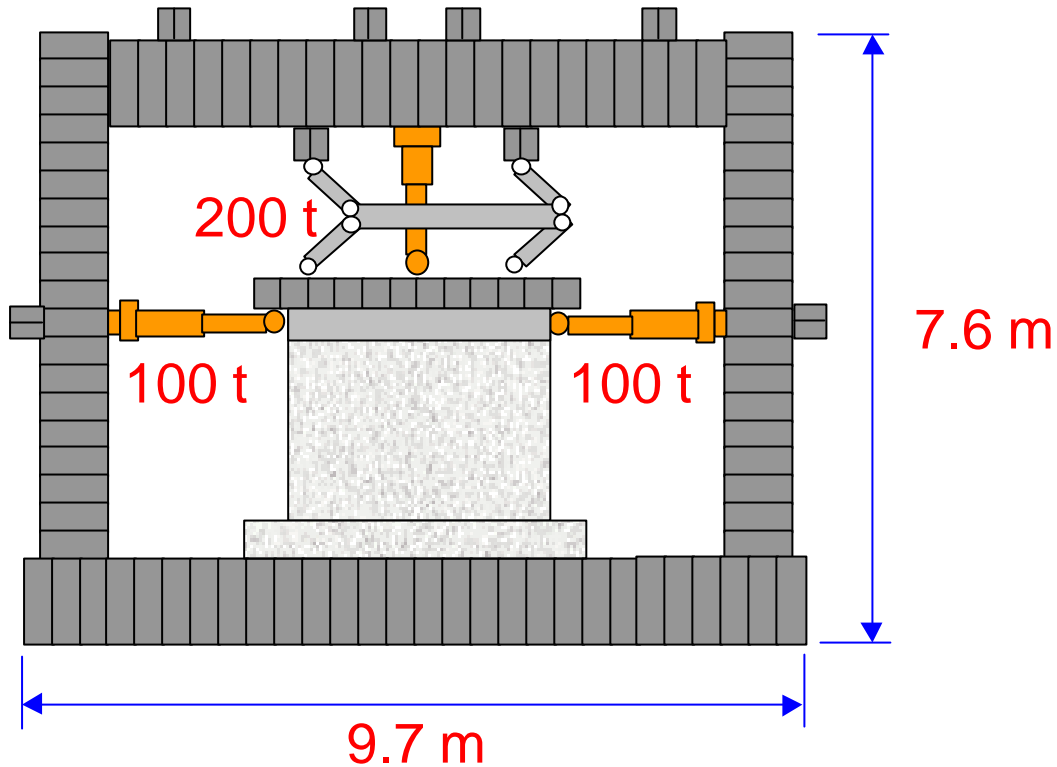

Reaction frame to be installed at UTCB

Reaction frame in *Building Research Institute*, Tsukuba, Japan

The equipments for strong ground motion observation will be placed on a path that follows the directivity of the maximum seismic energy from Vrancea seismic source. The accelerometers will be placed in free-field outside Bucharest and in boreholes and buildings inside Bucharest.

The equipments for soil testing and investigation consist of drilling equipment, SPT/CPT testing equipment, borehole sensors, data acquisition and processing systems and triaxial testing equipment.

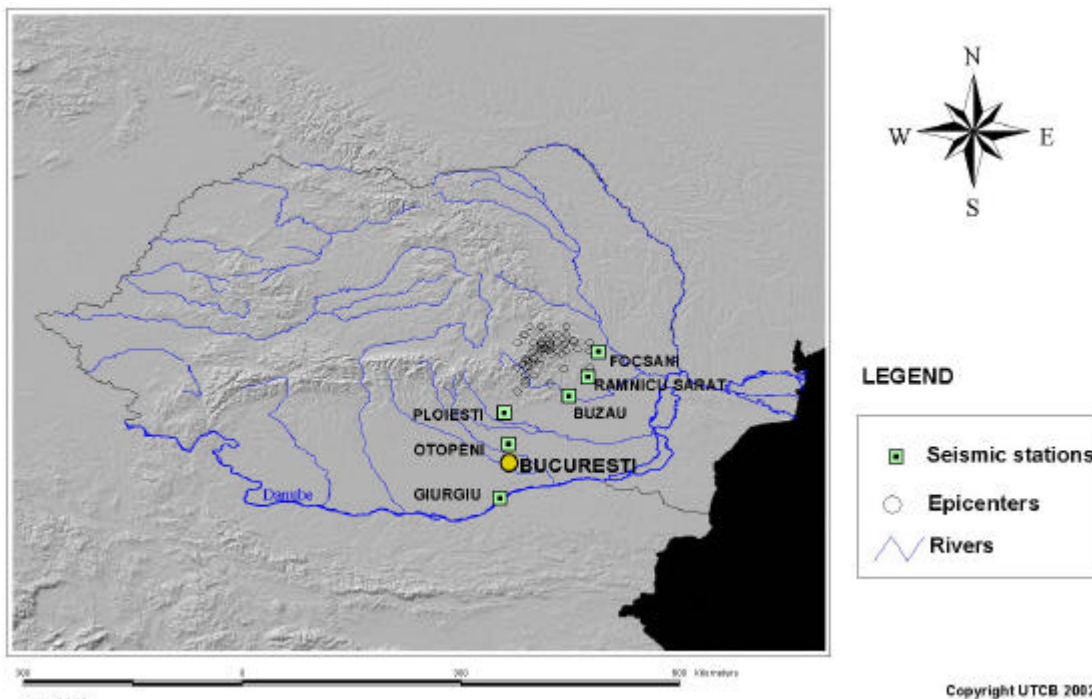

Seismic instrumentation outside Bucharest to be installed within the *Project*

The objectives of strong motion observation and soil testing and investigation equipments are:

- ✓ Data collection on ground motion to examine the characteristics of earthquakes;
- ✓ Soil condition investigation and seismic hazard investigation in Bucharest to develop the city microzonation;
- ✓ Data collection on seismic building response to examine the buildings behaviour;
- ✓ Revision of strong ground motion design parameters and developing new models for strong ground motion simulation.

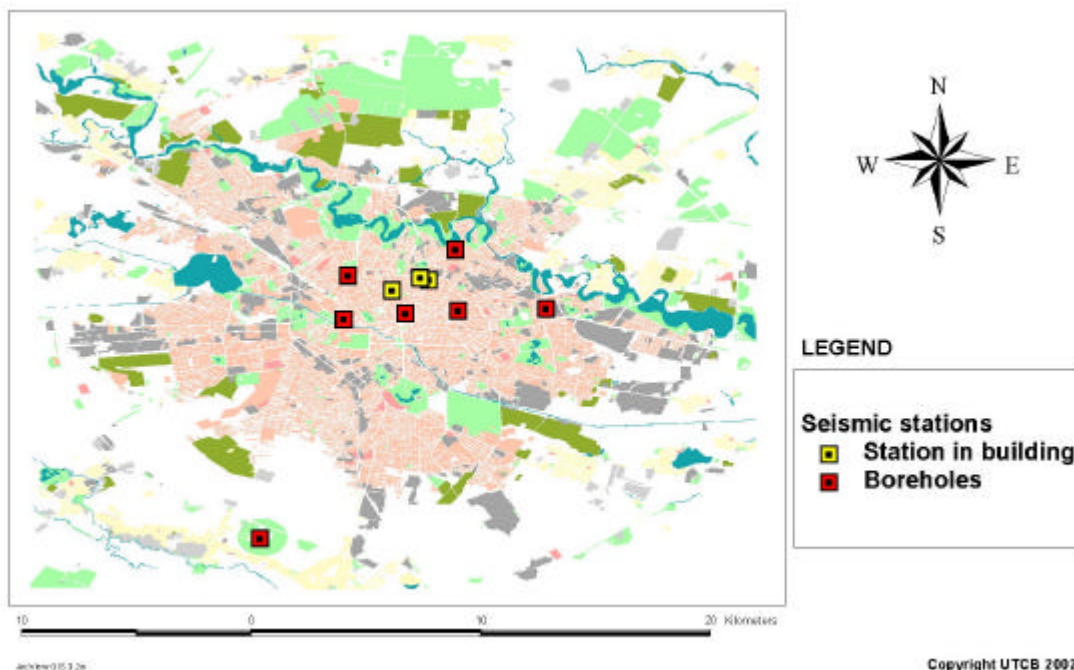

Seismic instrumentation inside Bucharest to be installed within the *Project*

.....
 Ó Newsletter of NCSRR. English Edition. Contact person: Dr. E.S. Georgescu, e-mail: ssever@cons.incerc.ro

Visit us at: www.utcb.ro/cnrns_en/cnrns.html